

**ERGO LINE (GN 1/1)**  
**Duo - Neutral - Heating Fan**



- ✓ **Two Boxes in Side-By-Side Configuration**
- ✓ **Superb Insulation Values**
- ✓ **Outstanding Manouverability**

ScanBox Ergo Line - Duo - Neutral - Heating - Fan is a range of products suited perfectly for any commercial kitchen operation requiring hot and cold holding or transport capacity. Designed with two fully seperated box compartments in a side by side configuration. Intuitive controls, ergonomic design and a wide range of different sizes and accessories will gurantee a perfect match with your operation. Designed with ScanBox latest Environmental Performance (ExP) technology combining increased performance with a decreased environmental impact. Designed to fit equally well back of house as well as front of house allowing exterior branding options.



**Function**

Two boxes positioned side by side, equipped with a fan heating system that provides an exact and even heat distribution. The heater is safely positioned in the back of the unit where also the power plug is located. Adjustable temperature and moisture ventilation allows you to be in control of food quality. Heat up time approximately 15 minutes with quick heat recovery in case of frequent door

Standard Equipment	Options
Backmounted Heating S/S Heater	International Plugs
Adjustable Temperature	
Adjustable Moisture Vent	
European Plug Type	

**Capacity**

Equipped with detachable stainless steel racks allowing the air to circulate freely inside the cavity. The u-shaped racks has a tilt-stop function securing the foodcontainer and lid during loading, unloading and transport. Variety of sizes and rack configurations allowing optimal usage of the box.

Standard Equipment	Options
GN 1/1 80 mm distance	Optional level distance
Detachable Racks	
Tilt-Stop Function	

**Mobility**

Lightweight, yet heavy duty. A solid design made for all types transports including truck. Equipped with non-marking, high quality double bearing castors for easy manouverability even in cramped spaces. Precision moulded PPE insulation assures food temperature and safety when the box is not plugged into power.

Standard Equipment	Options
Ø160 mm Castors	Optional Sized Castors
Double Bearing Castors	Stainless Steel Castors
Transport Handles *4	Tow Bars

**Ease of Use**

Equipped with an intuitive and easy to use display conviniently positioned in front top of unit. All-around top frame allows easy handling facing the unit from any direction. The 4,5 meter long single phase spiral cord is positionned on the back of the unit.

Standard Equipment	Options
One Grip Handle	Sight window/Glass door
Extra Long Spiral Cord	Tray holder foldable
Digital Controller in Front	
Central brake system	

**Construction**

A heavy duty yet lightweight construction based on a stainless steel framing, reinforced plastic exterior panels, solid high precision moulded polyrethane foam insulation and anonized aluminium interior. A smooth, hygienic and fully sealed inner cavity without welds or rivets. The frame, top hood and handles are in robust stainless steel.

Standard Equipment	Options
Smooth Hygienic Cavity	
Smooth S/S Top	
S/S Framing	

**Exterior Design**

Robust and elegant Scandinavian design made for both back of house as well as front of house operations. Possibility to choose different colours as well as adapting parts or the full box according to corporate branding. Use the design and let the box be a part of the full F&B experience.

Standard Equipment	Options
Black Glossy Finish	Optional colors
Black (RAL 9005)	Signature concept

**Product Safety**

High quality product Made in Sweden with high level of engineering details to performance, safety and easy of use. Thorough quality and safety testing through external third party. CE marked with complimentary EMC, RoHS, REACH and electrical safety testing.





## Technical Specification

### Model Series



### ERGO LINE - Duo - Neutral - Heating Fan

#### Product Models

**NE08 + HF08**
**NE12 + HF12**
**NE14 + HF14**

#### Article Number

**ELDNF08**
**ELDNF12**
**ELDNF14**

#### Active Heating

Controller	Digital adjustable	Digital adjustable	Digital adjustable
Heat Source	Electric Element	Electric Element	Electric Element
Temperature Range	Ambient up to 90°C	Ambient up to 90°C	Ambient up to 90°C
Heating Time *1	20 min	30 min	20 min
Energy consumption to operating temp *2	0,25 kWh	0,20 kWh	0,25 kWh

#### Capacity

Standard	GN 1/1	GN 1/1	GN 1/1
Pitch between levels	80 mm	80 mm	80 mm
Number of 65 mm containers	8	12	14
Number of 100 mm containers	5	8	9
Number of 150 mm containers	3	5	6
Maximum load per rack	9 kg	9 kg	9 kg
Maximum load in unit	72 + 72 kg	108 + 108 kg	126 + 126 kg
Max total weight (full unit)	230 kg	320 kg	360 kg

#### Physical Attributes

External dimensions (W x H x D) mm	1100 x 1065 x 810	1100 x 1385 x 810	1100 x 1545 x 810
Internal dimensions (W x H x D) mm	352 x 727 x 600	352 x 1047 x 600	352 x 1207 x 600
Volume	154 + 154 Liter	221 + 221 Liter	255 + 255 Liter
Net weight (empty unit)	90 kg	105 kg	115 kg
Door opening	270°	270°	270°
Length of Powercable	4,5 m	4,5 m	4,5 m

#### Electrical Attributes

Rated Voltage	220-240V / 1 phase	220-240V / 1 phase	220-240V / 1 phase
Rated Frequency	50-60 Hz	50-60 Hz	50-60 Hz
Rated Current	3,19 A	4,5 A	4,5 A
Power rating	700 W	1000 W	1000 W
IP Code *3	44	44	44

#### Dimension drawings

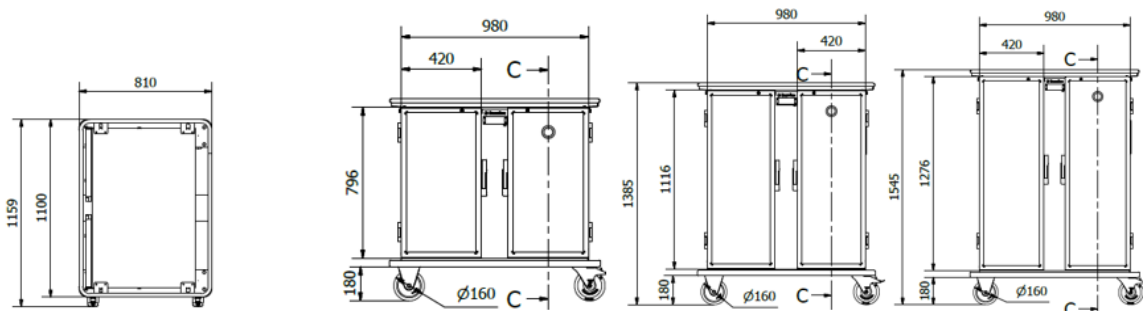

\*1 - Time for a hot unit to reach 80 ° C and for a cold unit to reach 5 ° C average temperature in the air in the cavity with 22 ° C ambient temperature.

\*2 - Operating temperature in hot unit of 80 ° C and in cold unit of 5 ° C with 22 ° C ambient temperature.

\*3 - IP44 = Protection against penetration of solid objects larger than 1 mm and protected against splashing water from all angles (IEC 60529)

\*4 - Recessed handles standard on ELDNF12 + ELDNF14